

# **High Power EDFA for FTTH / FTTB**

## **1550nm EDFA**

**(power supply:48VDC/110VAC/220VAC)**



## **Operating Manual**

**High power amplifier**

# Catalog

Using Safety Precautions .....	1
Application .....	2
Feature .....	2
Description: .....	2
Block Diagram .....	3
Optical characteristics .....	4
Environmental characteristics .....	4
Electrical Characteristics .....	4
Starting up .....	5
Equipment Powered Instructions .....	5
LED/ Key Description .....	5
Display Menu Description .....	5
Indicator .....	7
Interface .....	7
Web.....	8
Device Infomation.....	9
Network Config.....	10
UserManagement.....	11
SNMP Config.....	12
SNMP.....	13
Laser Safety Information.....	13
Order Information .....	14
Contact .....	14

## Using Safety Precautions

Before installing and using this product, please read the following carefully. The Company does not assume any responsibility for any loss due to security breaches caused.



Lasers and erbium-doped fiber amplifier output power laser radiation is not visible, can not look directly at the device connector end when it works to avoid burning eyes and skin.



Equipment includes precision optics, in order to avoid damage to the severe impact of its constitution, please avoid excessive vibration and impact. Pigtail easily sacrificed, so be careful.



Equipment containing electrostatic sensitive devices, handle it carefully and make sure the ground is good, the power supply is normal.

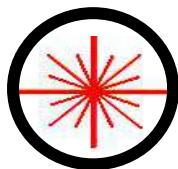

### Attention of optic fiber end face:

- 1、 Before using, please be sure to keep the input and output end face of the optic fiber clean, especially if the output end face is dirt, then it is easy to make the output end face burned and the output power will be decreasing. When cleaning the optical fiber end face or insert patch cords, please turn off the input light first.
- 2、 The correct order of plugging optical port is:  
Inserting: first insert optical patch cord of output port, then insert optical patch cord of input port.  
Pulling out: first pull optical patch cord of input port, then pull optical patch cord of output port.
- 3、 This kind amplifier is a high precision and high stability product, in order to have high stability output power, please use optical patch cord with good quality and which connectors are match with the device to connect with the output port. In principle, the optical patch cord should be as short as possible, and do not let it voluntary movement.



If there are any questions, please contact our company. Do not disassemble the module, otherwise it will cause irreparable damage.

## Application

- ◆ Analog CATV Transmission
- ◆ FTTH Optical Access
- ◆ Optical Distribution
- ◆ Free Space Optical
- ◆ R&D and Training

## Feature

- ◆ High Power: Up to 2W total, 1 Unit for 2000~4000 optical node
- ◆ Low Noise Figure: Below 5.5dB ( +5dBm input)
- ◆ Er Yb co-doped DCF Amplify Technology: Patent Pump Dump Technology
- ◆ Low CSO: <-70dBc
- ◆ 23dBm×N, 20dBm×N or 17dBm×N output is optional
- ◆ Controllability and maneuverability: Dual CPU to deal Control loop and Communication separately
- ◆ High Stability And Reliability: MTTF>150000 Hours
- ◆ Redundancy Hot Swap power module: 110/220VAC and 48VDC can plug Mix
- ◆ Perfect Network Interface: Ethernet
- ◆ Support SNMP network management
- ◆ Intelligent Temperature Control System: using a dedicated Temperature control chip which make cooling and power loss reduce 30% than competitors
- ◆ Output Power can be Adjustable by network and manual
- ◆ Integrated 1310nm, 1490nm, 1550nm WDM (Optional)
- ◆ OEM, Module is available

## Description

The product is high output power C-Band Er-Yb co-doped double cladding optical fiber amplifier. The key components of the product are high reliability multimode PUMP laser and the double cladding optical fiber. A proprietary ATC (Automatic Temperature Control) and APC (Automatic Power Control) circuit insures the high stability and reliability output power, the unique optical circuit design ensures the excellent optical performance. The high stability and high precision MPU system to ensure the control, adjustment and display are intelligent and easy.

This amplifier employ double cladding Erbium Ytterbium co-doped fiber, and employ the high power multimode pump, with a 10 times Conversion efficiency higher than the single mode general technology, and therefore have a lower relative cost and more compact size and lower power consumption, in particular, for FTTH or FTTB or other large distribution system applications.

Employ intelligent temperature control system: (1)Adopt special temperature control circuit, heat radiating and power consumption can be reduced 30%, (2)The professional air flow design can also ensure the best temperature stability, at the same time powerful fan will start when the case temperature is over 45 °C , meanwhile it will stop as the temperature is under 40 °C .The technology makes sure the thermal stability of system and fan' s long life.

Intelligent network management system. Perfectly network interface: Ethernet network, and the open network management interface ensure the connectivity with all other network management system.

These products are widely used in CATV transmission system and the high power distributing system FTTH requirement. It can be used for CATV analog/digital signal distribution, or match with PON system to

construction the triple network integration. (Triple wavelength WDM is optional)

### Block Diagram

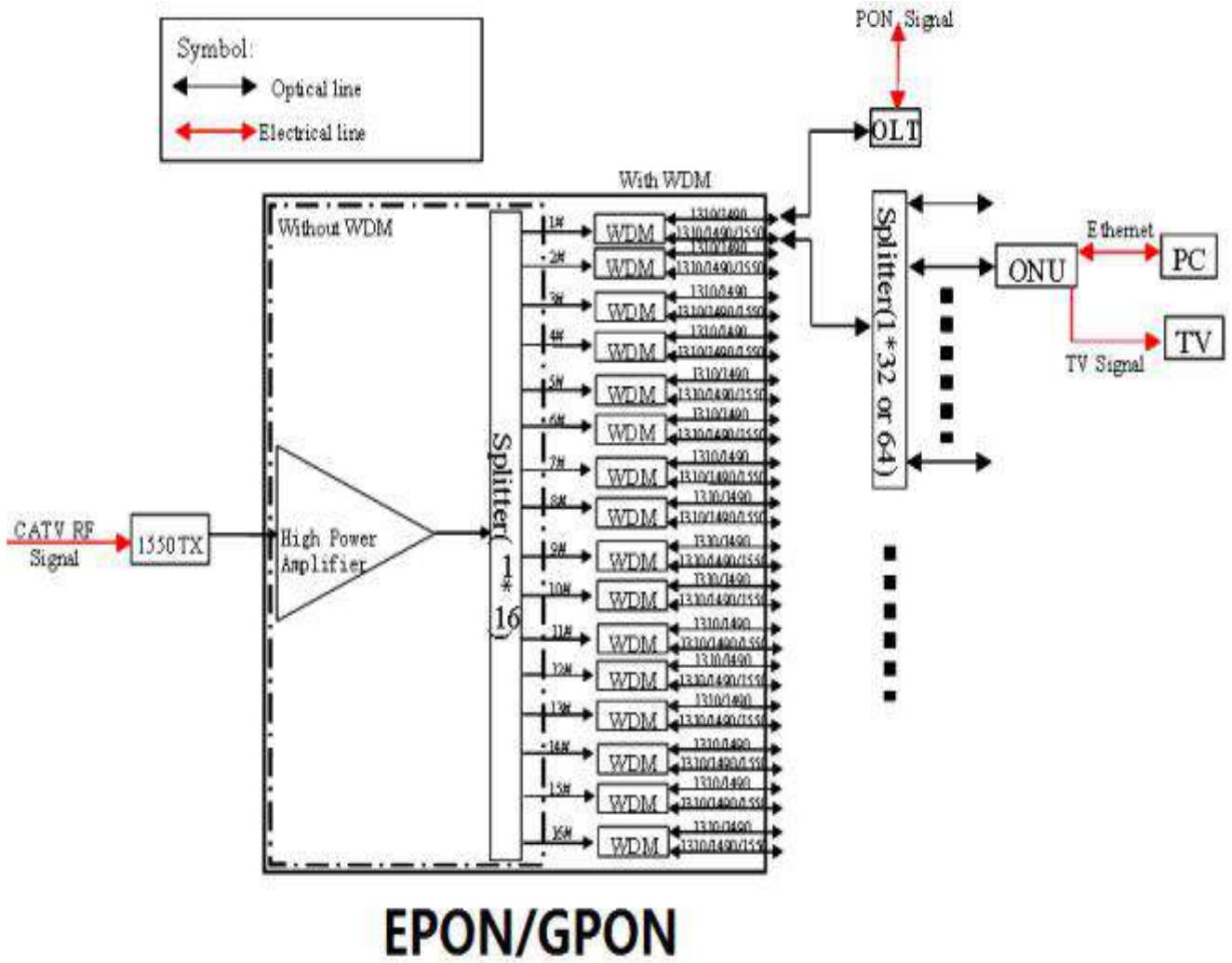
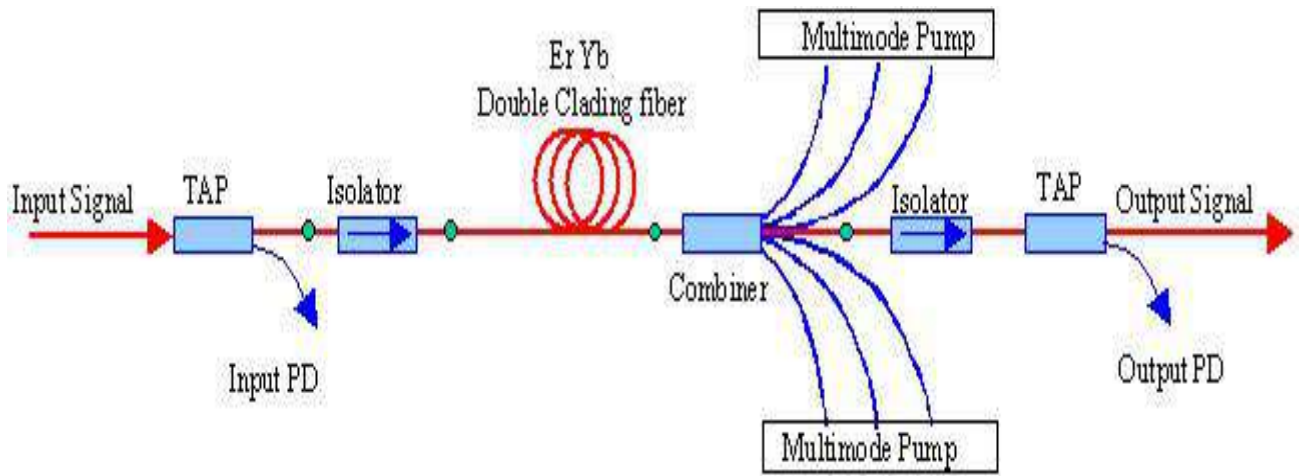

## Optical characteristics

Parameter	Symbol	MIN	TYP	MAX	UNITS
Operating Wavelength	$\lambda_c$	1540	1550	1565	nm
Saturated Output Power <i>Note1</i>	Po	13	-----	33	dBm
Input Power	Pi	-3	-----	+10	dBm
Gain	G	-----	-----	30	dB
Noise Figure <i>Note2</i>	NF	-----	-----	5.5	dB
Output Power Stability	$\Delta P_o$	-----	$\pm 0.05$	$\pm 0.2$	dB
Input Isolator	ISOi	30	-----	-----	dB
Output Isolator	ISOo	30	-----	-----	dB
Input Pump Leakage	PLi	-----	-----	-35	dBm
Output Pump Leakage	PLo	-----	-----	-45	dBm
Return Loss	RL	-----	-----	-45	dB
Polarization Dependent Gain	PDG	-----	-----	0.3	dB
Polarization Mode Dispersion	PMD	-----	-----	0.5	ps

Note 1: Optional

Note 2: Tested at +5dBm Input

## Environmental characteristics

Parameter	Symbol	MIN	TYP	MAX	UNITS
Operating Temperature	Tw	-5	-----	60	°C
Storage Temperature	Ts	-40	-----	80	°C
Humidity <i>Note</i>	-----	10	-----	90	%

Note: No Condensate

## Electrical Characteristics

Parameter	Symbol	MIN	TYP	MAX	UNITS
Power Supply (1)	Vps	170		264	VAC
Power consumption	P	-----	-----	50	W

1: 110VAC, 220VAC and -48VDC is optional, and duplicate supply is optional.

## Starting up

Before starting up, Please check the input voltage to the rated input voltage, grounding is good. The product adopts independent 220 VAC power supply.

## Equipment Powered Instructions

Special Note:

1. The power module must be properly inserted in the device, so it can be supplied power.
2. Do not insert the charged power module into the device directly.

## LED/ Key Description

- ▶ Device : Input power, output power, temperature, power supply , Fan status
- ▶ Pump : LD1 Current, Cooler, LD2 Current, Cooler
- ▶ Network : MAC, IP, MASK, Gateway, SNMP
- ▶ INFO : Part number, serial number, Website

## Display Menu Description

(1) Display device start up process when power on:

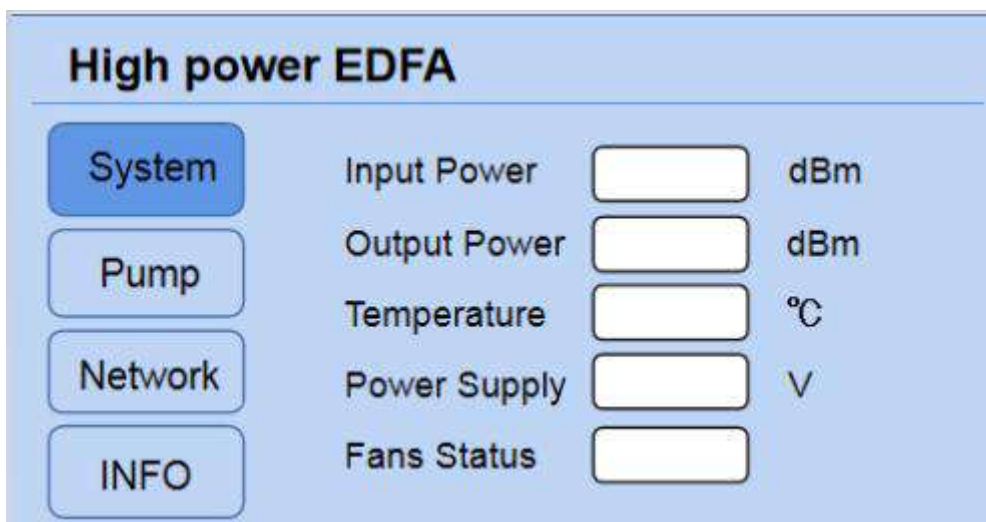
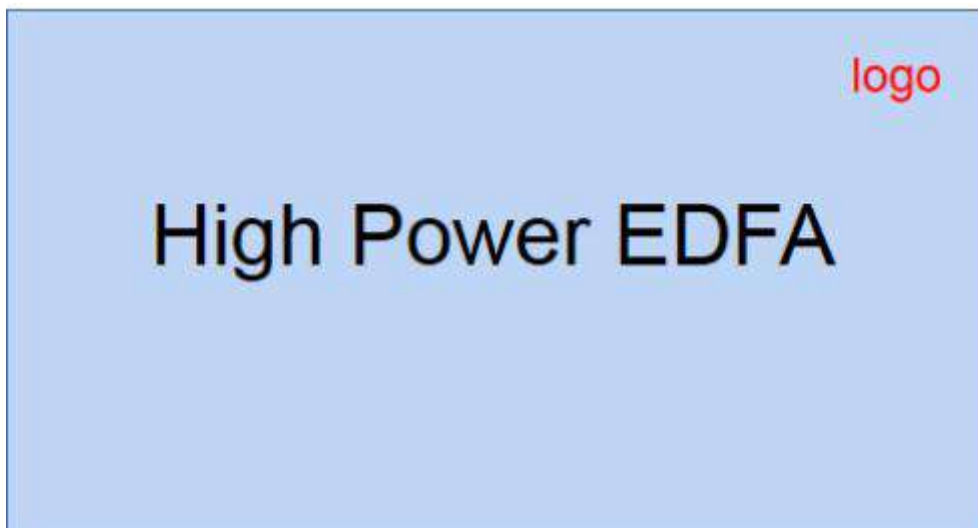

## High power EDFA

System	LD1 Current	<input type="text"/>	A
<b>Pump</b>	LD1 Cooler	<input type="text"/>	°C
Network	LD2 Current	<input type="text"/>	A
INFO	LD2 Cooler	<input type="text"/>	°C

## High power EDFA

System	MAC	<input type="text"/>
Pump	IP	<input type="text"/>
<b>Network</b>	MASK	<input type="text"/>
INFO	Gateway	<input type="text"/>
	SNMP	<input type="text"/>

## High power EDFA

System	Part Number	<input type="text"/>
Pump	Serial Number	<input type="text"/>
Network	Website	<input type="text"/>
<b>INFO</b>		

## Indicator

**Running:** working good this light on.

**Alarm:** Alarm Indicator: input and output light turns red when alarming.

## Interface

Front-Panel

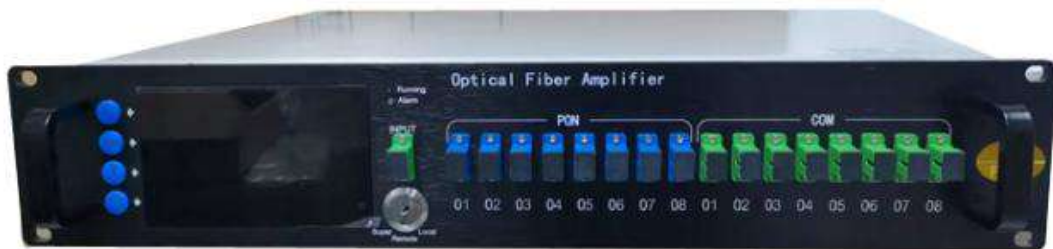

Back-Panel



## Connectors

	Description
Input	Optical input port
1~16	Optical output ports
RJ45	Web SNMP
Power1/2	Power input 110/220V AC OR 48 DC
Key	Local : Allow only local access and disable all network functions Remote: Support web SNMP Supper : Super manager Can perform remote power regulation, remote firmware upgrade ect

## Web Management

1: Open the browser URL and enter 192.168.1.1 to enter.



2: User name:admin

password :12345678

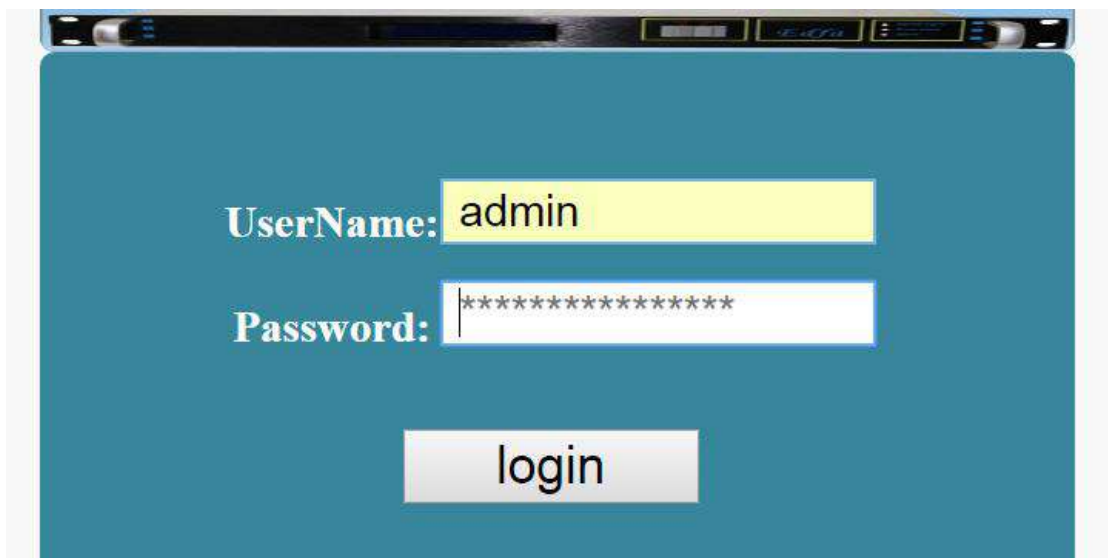

3: After entering, you will see the machine information.

The screenshot shows the 'Device Work Status' page. The left sidebar has 'DEVICE' selected. The main content area has a blue header with 'DEVICE', 'TCP/IP', 'FIREWALL', and 'MANAGEMENT'. Below the header, the page title is 'Device Work Status'. A sub-header reads: 'This page shows the current status and some basic settings of the device.' Below this is a table of device parameters:

Device	
PowerMode	Power1
LaserCount	1
LaserType	01
InputPower	2.10
OutputPower	21.90
SystemStatus	OK
Laser	
Bias(mA)	210.70
TEC(mA)	52.10
Temperature(c)	25.04
Power	
Type	Voltage
DC+5V-1	5.01
DC+5V-2	5.02

4: Lan interface setup

The screenshot shows the 'LAN Interface Setup' page. The left sidebar has 'LAN SETTING' selected. The main content area has a blue header with 'DEVICE', 'TCP/IP', 'FIREWALL', and 'MANAGEMENT'. Below the header, the page title is 'LAN Interface Setup'. A sub-header reads: 'This page is used to configure the parameters for local area network which connects to the LAN port of your Access Point. Here you may change the setting for IP addresss, subnet mask, DHCP, etc..'. Below this is a form with the following fields:

- IP Address:
- Subnet Mask:
- Default Gateway:
- DHCP:
- DHCP Client Range:  -
- DHCP Lease Time:  (1 ~ 10080 minutes)
- Static DHCP:
- Clone MAC Address:

At the bottom of the form are three buttons: , , and .

## 5: SNMP Setting

The screenshot shows the 'SNMP Setting' page in a web interface. The page has a blue header with navigation tabs: 'DEVICE', 'TCP/IP', 'FIREWALL', and 'MANAGEMENT'. The 'SNMP' tab is selected. The main content area is titled 'SNMP Setting' and includes a description: 'SNMP is a application for network management'. Below this, there is a checkbox labeled 'Enable SNMP' which is checked. The configuration fields are as follows:

Name :	<input type="text" value="EDFA"/>
Location :	<input type="text" value="ROOM"/>
Contact :	<input type="text" value="0"/>
Read/Write Community :	<input type="text" value="public"/>
Read-Only Community :	<input type="text" value="public"/>
Trap1 :	<input type="text" value="0.0.0.0"/>
Trap2 :	<input type="text" value="0.0.0.0"/>
Trap3 :	<input type="text" value="0.0.0.0"/>

At the bottom of the form, there are three buttons: 'Save', 'Save & Apply', and 'Reset'.

## 6: Access Point status

The screenshot shows the 'Access Point Status' page in a web interface. The page has a blue header with navigation tabs: 'DEVICE', 'TCP/IP', 'FIREWALL', and 'MANAGEMENT'. The 'MANAGEMENT' tab is selected. The main content area is titled 'Access Point Status' and includes a description: 'This page shows the current status and some basic settings of the device.' Below this, there are two sections of information:

**System**

Firmware Version	v3.4.11d
Build Time	Fri Jul 14 13:15:33 CST 2023

**TCP/IP Configuration**

Attain IP Protocol	Fixed IP
IP Address	192.168.1.1
Subnet Mask	255.255.255.0
Default Gateway	192.168.1.1
DHCP Server	Disabled
MAC Address	00:e0:4c:81:01:11

## 7. Statistics

The screenshot shows a web interface with a blue sidebar on the left containing menu items: STATUS, STATISTICS (highlighted), UPGRADE FIRMWARE, PASSWORD, and LOGOUT. The main content area has a top navigation bar with tabs: DEVICE, TCP/IP, FIREWALL, and MANAGEMENT (highlighted). Below the navigation bar, the page title is "Statistics" in green. A descriptive text reads: "This page shows the packet counters for transmission and reception regarding to wireless and Ethernet networks." Below this text is a table with the following data:

Interface	Packet Type	Count
Ethernet LAN	Sent Packets	492
	Received Packets	891

Below the table is a "Refresh" button.

## 8. Upgrade

The screenshot shows a web interface with a blue sidebar on the left containing menu items: STATUS, STATISTICS, UPGRADE FIRMWARE (highlighted), PASSWORD, and LOGOUT. The main content area has a top navigation bar with tabs: DEVICE, TCP/IP, FIREWALL, and MANAGEMENT (highlighted). Below the navigation bar, the page title is "Upgrade Firmware" in green. A descriptive text reads: "This page allows you upgrade the Access Point firmware to new version. Please note, do not power off the device during the upload because it may crash the system." Below this text, the "Firmware Version" is displayed as "v3.4.11d". The "Select File:" label is followed by a file selection button labeled "选择文件" and a text input field containing "未选择任何文件". At the bottom, there are "Upload" and "Reset" buttons.

## 9.Password Setup

	DEVICE	TCP/IP	FIREWALL	MANAGEMENT
STATUS	<h3>Password Setup</h3> <p>This page is used to set the account to access the web server of Access Point. Empty user name and password will disable the protection.</p>			
STATISTICS				
UPGRADE FIRMWARE				
PASSWORD	<p>User Name: <input type="text"/></p> <p>New Password: <input type="text"/></p> <p>Confirmed Password: <input type="text"/></p> <p><input type="button" value="Save"/> <input type="button" value="Save &amp; Apply"/> <input type="button" value="Reset"/></p>			
LOGOUT				

## 10.Logout

	DEVICE	TCP/IP	FIREWALL	MANAGEMENT
STATUS	<h3>Logout</h3> <p>This page is used to logout.</p>			
STATISTICS				
UPGRADE FIRMWARE				
PASSWORD				
LOGOUT	<p>Do you want to logout ?</p> <p><input type="button" value="Apply Change"/></p>			

## SNMP Management

SNMP Version 1 protocol is supported. The device related mib are defined as below.

mib	function
1.3.6.1.4.1.17409.1.11.2.0	Optical Input Power value*0.1dBm
1.3.6.1.4.1.17409.1.11.3.0	Optical Output Power value*0.1dBm
1.3.6.1.4.1.17409.1.11.4.1.2.1	Bias Current.1 value*1mA
1.3.6.1.4.1.17409.1.11.4.1.2.2	Bias Current.2 value*1mA(Reserved)
1.3.6.1.4.1.17409.1.11.4.1.2.3	Bias Current.3 value*1mA(Reserved)
1.3.6.1.4.1.17409.1.11.4.1.3.1	Tec Current.1 value*0.1A
1.3.6.1.4.1.17409.1.11.4.1.3.2	Tec Current.1 value*0.1A(Reserved)
1.3.6.1.4.1.17409.1.11.4.1.3.3	Tec Current.2 value*0.1A(Reserved)
1.3.6.1.4.1.17409.1.11.4.1.4.1	Pump Temperature.1 value*0.1deg
1.3.6.1.4.1.17409.1.11.4.1.4.2	Pump Temperature.1 value*0.1deg(Reserved)
1.3.6.1.4.1.17409.1.11.4.1.4.3	Pump Temperature.2 value*0.1deg(Reserved)
1.3.6.1.4.1.17409.1.11.7.1.2.1	DCPower Voltage.1 value*0.1V
1.3.6.1.4.1.17409.1.11.7.1.2.2	DCPower Voltage.2 value*0.1V
1.3.6.1.4.1.17409.1.3.1.13.0	Internal Temperature value*1deg
1.3.6.1.4.1.17409.1.3.3.2.2.1.12.1	Device Temperature value*1deg

## Laser Safety Information

Class IV laser products.

9μm/125μm single-mode fiber pigtail with connector.

Wavelength=0.90~1.68μm

Maximum Power=10W

**Caution:** Use of controls, adjustments, and procedures other than those specified herein may result in hazardous laser radiation exposure.



## Order Information

Category	Application	Input Power	—	Output Power	—	ports	Power supply1	Power supply2	Interface	Network Management
<b>EDFA-1500</b>	<b>1</b>	<b>X</b>	—	<b>20</b>	—	<b>64</b>	<b>2</b>	<b>4</b>	<b>2</b>	<b>0</b>
1U/ 2U/3U Rack	1: CATV	1:-3~+10dBm;		13:13dBm		1:1 port	1: 110VAC	1: 110VAC	1:SC/UPC	0: None
Dual power	2: DCM	2:+5~+15dBm;		24:24dBm		2:2 port	2: 220VAC	2: 220VAC	2:SC/APC	1: SNMP
supply	3:Telecom single channel	3:0~+10dBm;				4:4 port	4: -48VDC	4: -48VDC	3:FC/UPC	
	4:Telecom DWDM	4:-8~+10dBm;				8:8 port		0: None	4:FC/APC	
	5:Wide Band single Channel	5:-35dBm~-25dBm(				16:16 port			5:LC/UPC	
		Pre):				32:32 port			6:LC/APC	
		6:-25dBm~-10dBm(				64:64 port				
		Online):								
		7:-10dBm~+6dBm(								
		Booster):								
		9:Other								

**Note 1: EDFA-1500 for 1U rack, Maxim ports number: 16 (w/ WDM) , or 32 (w/o WDM)**

**Note 2: High End configure with SNMP Net management.**

**Note 3: 2U and 3U rack maxim 64 port with WDM**